



KOMPLETTWERKZEUG ZUM WECHSEL DER HYDROLAGER

Arbeitsbereich: HA Achsschenkel Ø 47



| | | | | | | |
|---------------------|----------|---------|----------|---------|---------------|---------|
| Passend für: | BMW E-46 | ab `05 | BMW F-23 | 14 - 21 | BMW F-83 | ab `19 |
| | BMW E-81 | 06 - 12 | BMW F-25 | ab `10 | BMW G-20 | ab `18 |
| | BMW E-82 | 06 - 13 | BMW F-26 | ab `14 | BMW G-22 | ab `20 |
| | BMW E-84 | 09 - 15 | BMW F-30 | 11 - 18 | BMW G-23 | ab `20 |
| | BMW E-87 | 03 - 13 | BMW F-31 | 12 - 19 | BMW G-28 | ab `18 |
| | BMW E-88 | 07 - 13 | BMW F-32 | ab `13 | BMW G-80 | ab `18 |
| | BMW E-90 | 04 - 12 | BMW F-33 | ab `19 | BMW G-82 | ab `20 |
| | BMW E-91 | 04 - 12 | BMW F-34 | ab `12 | BMW G-83 | ab `20 |
| | BMW E-92 | 05 - 13 | BMW F-35 | ab `11 | Opel Vectra C | 02 - 09 |
| | BMW E-93 | 06 - 13 | BMW F-36 | ab `14 | Opel Signum | 03 - 08 |
| | BMW F-20 | 11 - 19 | BMW F-80 | 11 - 18 | Fiat Croma | 05 - 11 |
| | BMW F-21 | ab `11 | BMW F-82 | ab `13 | Saab 9 - 3 | 02 - 15 |
| | BMW E-22 | 12 - 21 | | | | |

Arbeitsbereich: HA Achskörper Ø 49



| | | | | |
|---------------------|----------|---------|----------|---------|
| Passend für: | BMW E-38 | 94 - 01 | BMW E-60 | 01 - 10 |
| | BMW E-39 | 95 - 04 | BMW E-61 | 04 - 10 |
| | BMW E-52 | 00 - 03 | BMW E-63 | 03 - 10 |
| | BMW E-53 | 00 - 06 | BMW E-64 | 04 - 10 |

Artikel-Nr.: 33 920 300

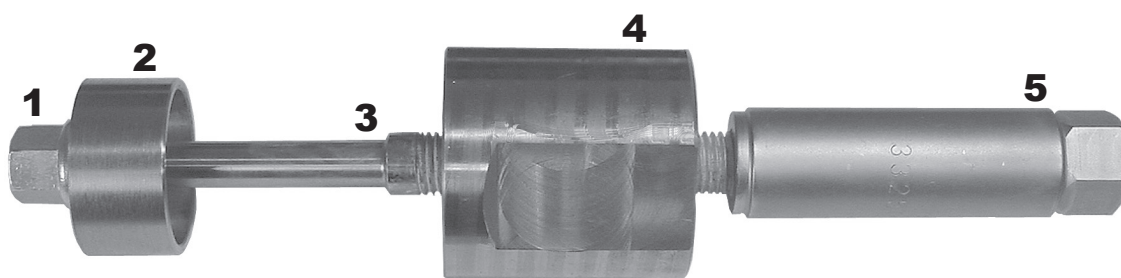

| Pos. | Artikel-Nr. | Bezeichnung |
|-----------|-------------|--|
| 1 | 905.3212 | Mutter M12 mit Bund |
| 2 | 33 920 602 | Druckstück |
| 3 | 33 902 623 | Zugbolzen M16 auf M12 (33 902 603, ..613) |
| 4 | 33 920 604 | Druckstück |
| 5 | 33 250 605 | Spezialmutter M16 |
| 12 | 33 303 622 | Druckstück m. Kugellager (Optional) (Für Einbau Ø 49) |

Optional!
 Um hydraulisch zu arbeiten:
 Zugbolzen 33 904 613 mit
 Mutter 905.3220 und
 Distanzhülse 33 903 604.



12

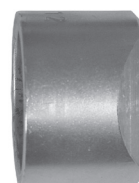

Im Lieferumfang sind die Positionen 1 bis 5 enthalten.

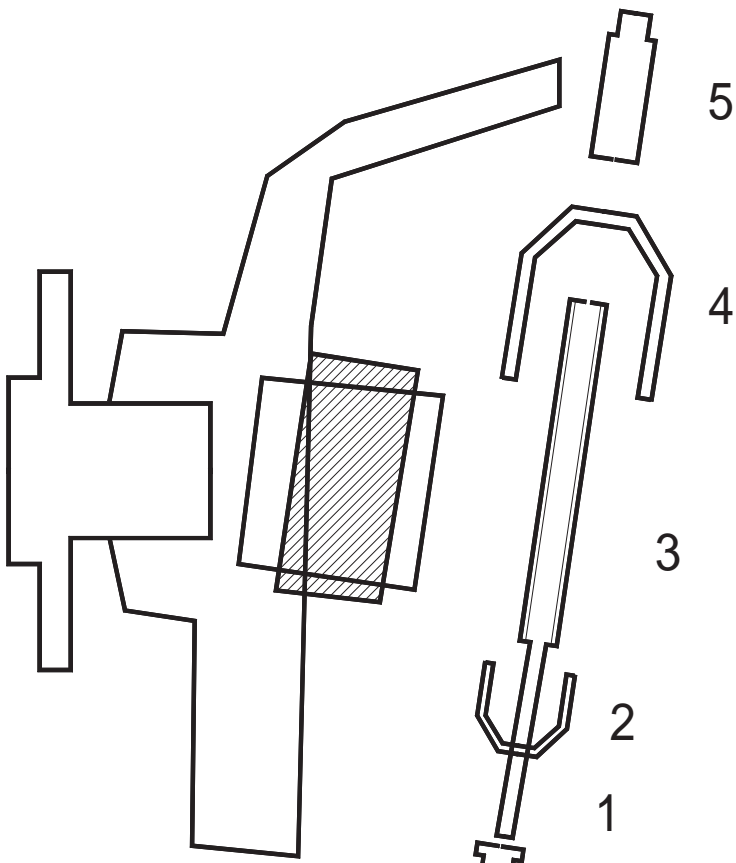

Ausbau

Einbau

